

SL34

SOLAR LED STREET / PARKING LOT / AREA LIGHT
35W To 135W LED Lamp - Complete System With Pole

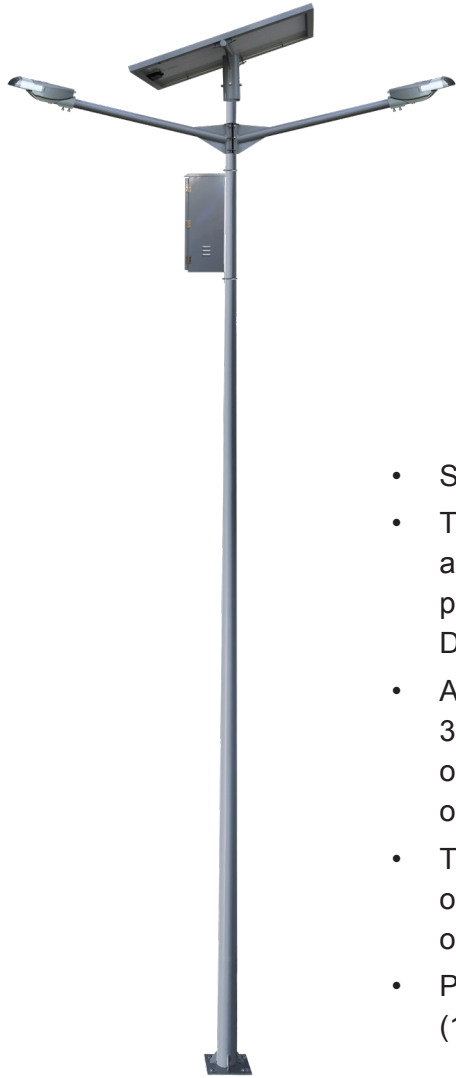

Modular design allows for longer life and greater efficiency.



LUMILEDS

Philips LUMILEDS® LUXEON T
Up to 185 lm/W efficiency.



- Sold as a complete, single lamp lighting system with a choice of pole.
- This system can be designed, engineered, and pre-programmed to automatically operate from dusk to dawn all year round. Or it can be programmed to operate for a single or dual timed modes instead. Dimming and motion detection are optionally available.
- Adjustable LED power between 35W to 135W. Typical options being 35W, 65W, 100W, or 135W with Type II, III, or V distribution. Light output from 6,475 to 24,975 lumens. Choice of warm white (3,000k) or daylight white (5,500k). Other CCT options by special order.
- The solar panel size (wattage) and battery size (capacity) is based on the total LED power, geographic location of the site, and the hours or times of nightly operation.
- Pole height options include 15' (4.5m), 20' (6m), 26' (8m), or 33' (10m). Custom pole heights by special order.



*SUBJECT TO OUR TERMS & CONDITIONS, AND RETURNS POLICY

Lowest Price*
Guarantee



Worldwide*
Shipping



10 Year*
System Warranty



20 Year*
Panel Warranty



Lifetime*
Tech Support



9120 Centerlinks Commerce Drive • Unit 3 • Fort Myers • FL • 33912 • USA • Telephone: 239-461-5522

MONDAY - FRIDAY 8:00AM - 8:00PM (US EASTERN TIME)

www.solarilluminations.com • sales@solarilluminations.com



SL34

SOLAR LED STREET / PARKING LOT / AREA LIGHT
35W To 135W LED Lamp - Complete Sytem With Pole

Solar Makes Sense

Using a solar lighting system is often **cheaper than trenching** cables to remote sites or through parking lots, under roads and sidewalks.



No monthly bills for electric usage, meter fees, or taxes.

Federal and local incentives may be available to offset the cost of the system. View our website for current incentives.



Renewable energy. Use the suns unlimited power as a clean source of renewable energy.

Green Image. Let people know your company or organization is doing its part in reducing its reliance on unclean energy.



Purchase with Confidence



Established in 2002 with offices and warehouse located in Fort Myers, Florida where we store, assemble, ship, and support our products.



We stand behind our systems with a 20 year limited warranty on the solar panels, and a 10 year limited warranty on the system.



Our superior customer service and support is proven with our A+ rating with the Better Business Bureau.



Technical support is available for life! We'll be here to assist you with support and troubleshooting if the need arises.

Lowest Price* **Worldwide*** **10 Year*** **20 Year*** **Lifetime***
Guarantee Shipping System Warranty Panel Warranty Tech Support

9120 Centerlinks Commerce Drive • Unit 3 • Fort Myers • FL • 33912 • USA • Telephone: 239-461-5522

MONDAY - FRIDAY 8:00AM - 8:00PM (US EASTERN TIME)

www.solarilluminations.com • sales@solarilluminations.com

*SUBJECT TO OUR TERMS & CONDITIONS, AND RETURNS POLICY



SL34

SOLAR LED STREET / PARKING LOT / AREA LIGHT

35W To 135W LED Lamp - Complete System With Pole



PHILIPS
LUMILEDS



LUXEON™
never before possible

DARK SKY
COMPLIANT LIGHTING
Full Cutoff Light Fixture



Philips LUMILEDS LUXEON T LED emitters produce up to 185 lumens per Watt efficiency and have a life span greater than 100,000 hours of operation.



135 Watt LED Lamp - Philips LUMILEDS® LUXEON T
Provides approx. 24,975 lumens of light output.

100 Watt LED Lamp - Philips LUMILEDS® LUXEON T
Provides approx. 18,500 lumens of light output.

65 Watt LED Lamp - Philips LUMILEDS® LUXEON T
Provides approx. 12,025 lumens of light output.

35 Watt LED Lamp - Philips LUMILEDS® LUXEON T
Provides approx. 6,475 lumens of light output.

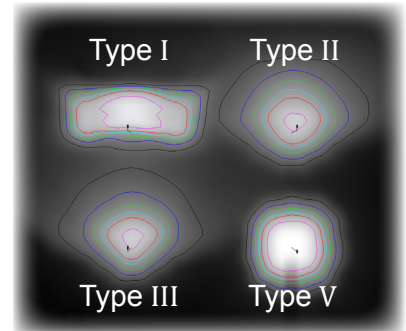

Each lamp is supplied in one of four different lighting distributions: Type I, II, III, or V.

The standard power ranges offered can be adjusted using the optional dimming feature of the charge controller. For example 100W lamp can be permanently reduced to 80W, or it can be reduced for a set period of time each evening. The illumination schedule and dimming feature can be customized to work for many different lighting scenarios.

- Configured with one or multiple LED modules each containing 14 Philips LUMILEDS® LUXEON T LEDs.
- LED color is daylight white (5,500K) or warm white (3,000K). Other CCT options available by special order.
- LED life expectancy is typically up to 100,000 hours or equal to about 22 years.
- LEDs are powered by Mean Well drivers, with integrated PWM dimming control and multi-driver redundancy.
- Full cut-off fixture. Dark sky compliant.

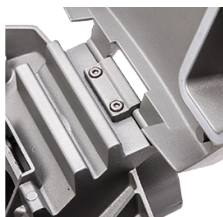

Easy Access to Driver and Connections



Vented Design for Ideal Heat Dissipation



Supplied with Stainless Steel Hardware



Adjustable Arm from 0°, 10°, or 15° for Increased Projection



*SUBJECT TO OUR TERMS & CONDITIONS, AND RETURNS POLICY

Lowest Price Guarantee ✓ **Worldwide Shipping** ✓ **10 Year System Warranty** ✓ **20 Year Panel Warranty** ✓ **Lifetime Tech Support** ✓

9120 Centerlinks Commerce Drive • Unit 3 • Fort Myers • FL • 33912 • USA • Telephone: 239-461-5522

MONDAY - FRIDAY 8:00AM - 8:00PM (US EASTERN TIME)

www.solarilluminations.com • sales@solarilluminations.com

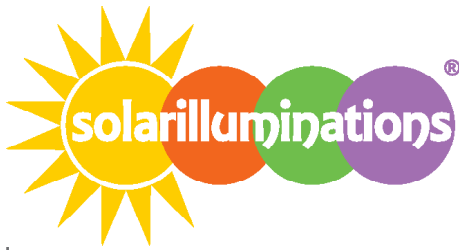

SL34

SOLAR LED STREET / PARKING LOT / AREA LIGHT

35W To 135W LED Lamp - Complete System With Pole



Solar Panel

Systems are supplied with high quality monocrystalline or polycrystalline solar panels with the highest performance and efficiency. They are designed to endure the harshest environments, and are guaranteed to provide power for well over 20 years. Typically manufactured in the USA, Canada, or Germany. The solar panel power is subject to LED consumption, installation location, and illumination period. Please consult with our engineers for specific solar power recommendations.

MC4 Connector



Photovoltaic Module

- Highly efficient monocrystalline or polycrystalline solar panel with aluminum frame, anti-aging, and encapsulated membrane.
- Anti-reflective and anti-soiling surface that reduces power losses from dirt and dust.
- Certified to withstand high wind loads (340PSI) and snow loads (780PSI); and resistance to high salt and ammonia.
- Manufactured to international standards, verified and certified by independent testing laboratories. (UL, ETL, IEC, MCS, & TUV)
- Assembled to strict quality control standards; international standards ISO 9001 and ISO 14001.
- Range of solar panel power available from 45W to +500W.
- The solar panel power is subject to LED consumption, installation location, and illumination period. Please consult our engineers for specific solar power requirements.
- Solar panels can be supplied in a single or dual format (2 x 70W = 140W, 2 x 100W = 200W etc.)
- Typical solar panel life is over 30 years, subject to environmental factors.

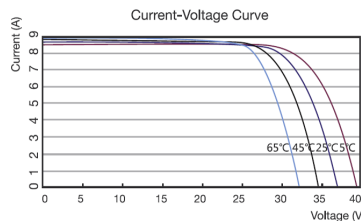
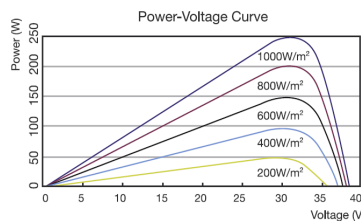
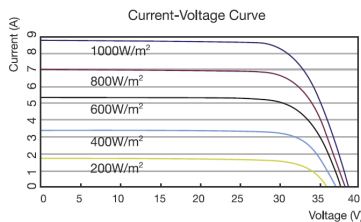

*SUBJECT TO OUR TERMS & CONDITIONS, AND RETURNS POLICY

Lowest Price Guarantee ✓ **Worldwide Shipping** ✓ **10 Year System Warranty** ✓ **20 Year Panel Warranty** ✓ **Lifetime Tech Support** ✓

9120 Centerlinks Commerce Drive • Unit 3 • Fort Myers • FL • 33912 • USA • Telephone: 239-461-5522

MONDAY - FRIDAY 8:00AM - 8:00PM (US EASTERN TIME)

www.solarilluminations.com • sales@solarilluminations.com

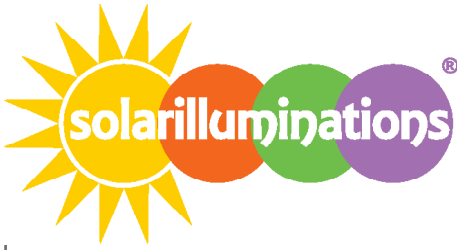

SL34

SOLAR LED STREET / PARKING LOT / AREA LIGHT

35W To 135W LED Lamp - Complete System With Pole



“EastPenn batteries are engineered and tested to provide reliable, long-lasting power for Photovoltaic (PV) and renewable energy applications where frequent deep cycles are required and minimum maintenance is desirable.”

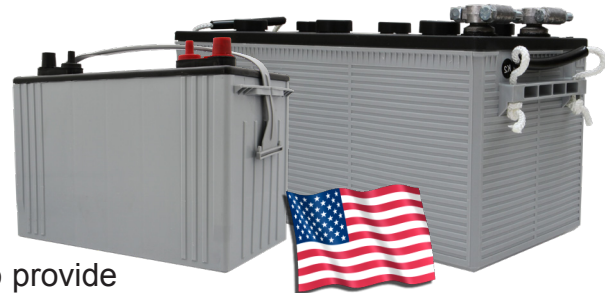

Made in the USA

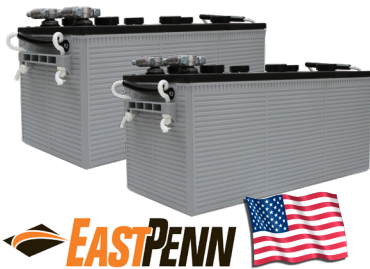

Battery

- Manufactured by: East Penn Manufacturing Co. Inc.
- 100% made in the USA.
- System supplied standard with two 12 Volt batteries. Batteries are wired in series to make a 24 Volt system.
- Available battery capacities range from 50Ah to 245Ah (per battery).
- Choice of two battery types: Absorbed Glass Mat (AGM) or Gel Cell.
- Please consult our engineers for specific battery capacity requirements.
- Classified as Non-spillable (defined by DOT, ICAO and IATA), NonHAZMAT, and valve regulate.
- Conforms to ISO9001, ISO/TS 16949, and ISO14001 standards.
- Typical battery life is approximately 5 to 7 years, subject to environmental factors.

VRLA Technology

VRLA batteries are maintenance free for life. VRLA stands for Valve Regulated Lead Acid, which means the batteries are sealed. Gas will only escape through the safety valves in the case of overcharging or cell failure.

AGM and Gel batteries have exceptional discharge recovery, even after deep or prolonged discharge. However, it should be noted that repetitive deep discharge and prolonged deep discharge have a negative influence on the service life of all lead acid batteries.

Gel batteries in general have a longer service life and better cycle capacity than AGM batteries.

Please Note: The rated capacity of our AGM or gel deep cycle batteries refer to 20 hour discharge rate (i.e. 0.05CA). Most products actually operate near, or at a 100 hour discharge rate (i.e. 0.01CA) and thus actual available battery capacity is slightly higher than the advertised rate.

The total available battery power is measured in watt-hour (Wh) or V*Ah. When comparing our total battery capacity with competitor's, please note that the battery capacity from a 12V system is not interchangeable with the battery capacity of a 24V system. However, the total battery power (i.e. watt-hours) is always comparable provided the correct system voltage is considered during calculation.

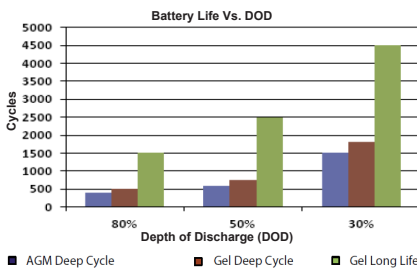
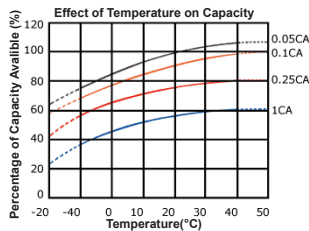

Lowest Price Guarantee Worldwide Shipping 10 Year System Warranty 20 Year Panel Warranty Lifetime Tech Support

9120 Centerlinks Commerce Drive • Unit 3 • Fort Myers • FL • 33912 • USA • Telephone: 239-461-5522

MONDAY - FRIDAY 8:00AM - 8:00PM (US EASTERN TIME)

www.solarilluminations.com • sales@solarilluminations.com

*SUBJECT TO OUR TERMS & CONDITIONS, AND RETURNS POLICY





SL34

SOLAR LED STREET / PARKING LOT / AREA LIGHT

35W To 135W LED Lamp - Complete System With Pole

Performance

Operating voltage is 24 volts. DC.
Power consumption is typically 35, 65, 100 or 135 watts (subject to model selected).
Operating temperature -40 deg. C ~ +80 deg. C (-40 deg. F ~ 175 deg. F).
Intelligent battery management software to prevent over-charging and over-discharging.
Includes a minimum of three to five days of autonomy (battery back-up).
Several successive cloudy or overcast days typically will not affect illumination time.
Supplied solar panel power is based on installation location and system requirements.
Illumination period can be designed to meet specific requirements.



Hardware & Pole

Battery Enclosure

- Galvanized steel lockable battery enclosure will accommodate the rechargeable batteries and charge controller (padlock not included.)
- Designed to conform to NEMA 3R and IP22 rating standards for Outdoor Enclosures. Offering protection against rain, snow, and sleet. Meets the requirements of UL 508 "Rainproof enclosures".
- The battery enclosure can be mounted onto, or at the base of the pole, subject to battery selection.
- Enclosures with batteries larger than 92Ah will need to be mounted at the base of the pole.
- The enclosure has pre-drilled holes to enable secure installation to a concrete pad.
- For pole mounting, the battery enclosure includes mounting plates with slots for U-bolts or stainless steel banding.
- Silver/gray color finish. Custom colors by special order.

Arm

- Galvanized steel arm mounts the luminaire to the light pole.
- Choice of arm length available.
- Can be attached in any direction and any height on the pole.
- Silver/gray color finish. Custom colors by special order only.

Pole

- Galvanized steel pole with square base plate for surface mounting.
- Anchor bolts and two templates are included. The 4 pre-drilled holes on each template are approx. 3/4" (20mm) diameter.
- Pole height options are 20' or 26' (6m or 8m). 33' (10m) and other sizes are available by special order.
- The top of the pole has an outside diameter of approximately 3.7" (96mm) and tapers outwards towards the base.
- Silver/gray color finish. Custom colors by special order only.
- The location, wind factor, and ground conditions will affect the size of the foundation required.



Lowest Price*
Guarantee

Worldwide*
Shipping

10 Year*
System Warranty

20 Year*
Panel Warranty

Lifetime*
Tech Support



*SUBJECT TO OUR TERMS & CONDITIONS, AND RETURNS POLICY

9120 Centerlinks Commerce Drive • Unit 3 • Fort Myers • FL • 33912 • USA • Telephone: 239-461-5522

MONDAY - FRIDAY 8:00AM - 8:00PM (US EASTERN TIME)

www.solarilluminations.com • sales@solarilluminations.com

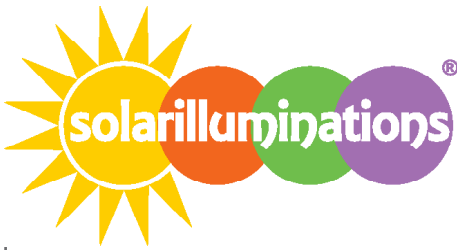

SL34

SOLAR LED STREET / PARKING LOT / AREA LIGHT

35W To 135W LED Lamp - Complete System With Pole

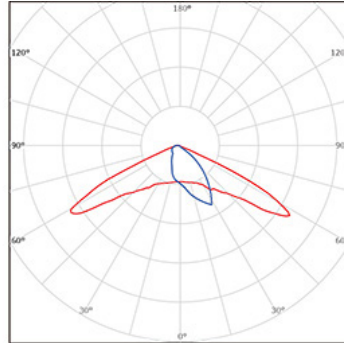
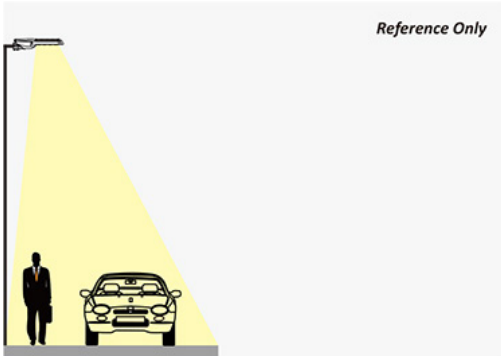

Type I

Applications:
 Narrow Roadways
 Pathways/sidewalks
 Single-track / One-Lane Roads

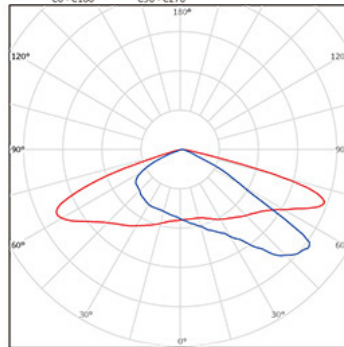
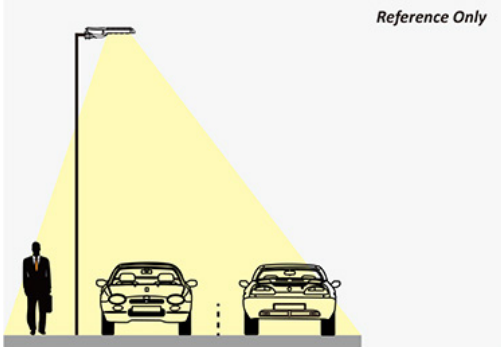
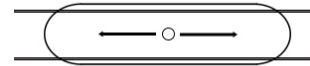

Type II

Applications:
 Urban Roadways
 Pathways/sidewalks
 Two-lane Expressways

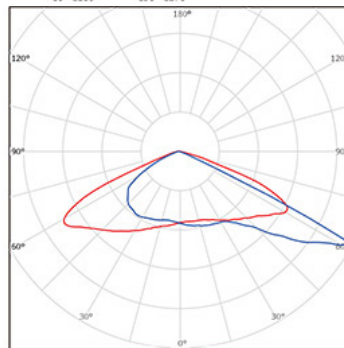
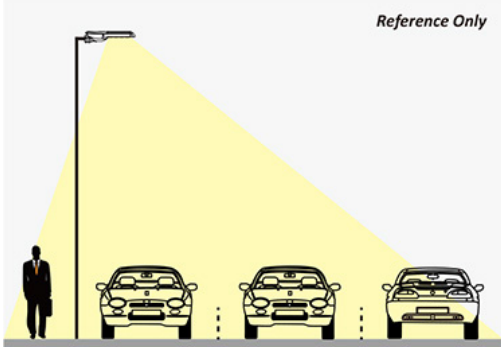
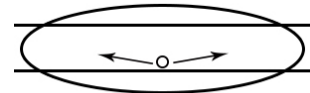

Type III

Applications:
 Highways
 Parking Lots
 Multi-lane Expressways

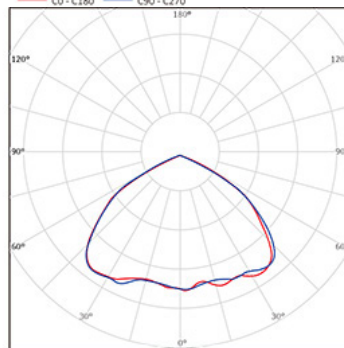
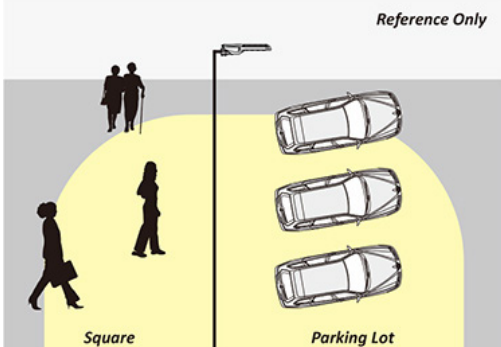
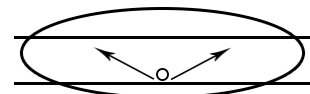

Type V

Applications:
 Parking Lots
 Area Lights

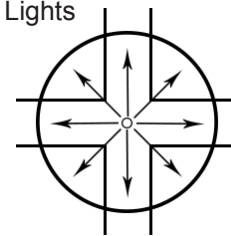

*SUBJECT TO OUR TERMS & CONDITIONS, AND RETURNS POLICY

Lowest Price* **Worldwide***
 Guarantee Shipping

10 Year* **20 Year***
 System Warranty Panel Warranty

Lifetime*
 Tech Support

9120 Centerlinks Commerce Drive • Unit 3 • Fort Myers • FL • 33912 • USA • Telephone: 239-461-5522

MONDAY - FRIDAY 8:00AM - 8:00PM (US EASTERN TIME)

www.solarilluminations.com • sales@solarilluminations.com



SL34

SL34 SOLAR LED STREET / PARKING LOT LIGHT
 35W, 65W, 100W, 135W LED Lamp & Complete Solar Sytem

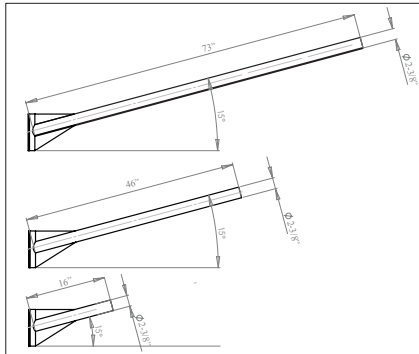

PART 2 | LIGHT ARM

20' Light Pole Steel Galvanized / Painted Anchor Base

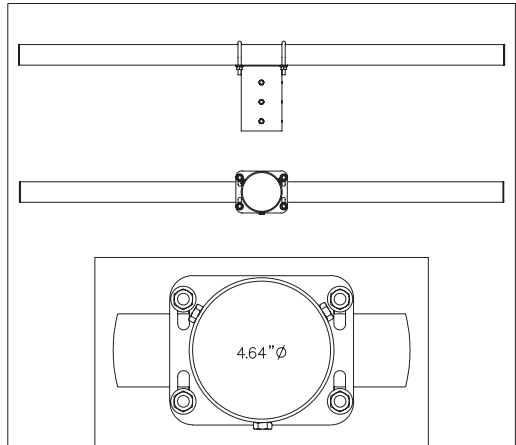

PART 1 | SOLAR PANEL TOP POLE MOUNT

MATERIAL DATA	
COMPONENT	ASTM
POLE SHAFT	A595 GR.55
BASE PLATE	A36
ANCHOR BOLTS	F1554 GR.55
MISC. STEEL	A36

LOADING DATA	
DESIGN CRITERIA:	COMMERCIAL STANDARD
WIND SPEED (MPH) 1.3 GUST	80 90 100 110 120 130 140 150
EPA FT2	24.2 19.3 15.6 13.5 11.2 9.5 8.1 6.9
WEIGHT (LBS)	605 482 390 335 280 238 203 173

POLE DIMENSION DATA				
POLE LENGTH (FT)	BASE DIAMETER (IN)	TOP DIAMETER (IN)	GAUGE OR THICKNESS (IN)	WEIGHT (LBS)
20'	6 - 1/2"	3 - 3/4"	11-GA (1/8")	175

Solar illuminations poles are engineered according to AASHTO standards and accepted commercial criteria. Proper selection for an application is based on information such as EPA, wind zone, mounting height, and product attachments. This information is necessary to ensure correct engineering. Solar illuminations assumes no responsibility for proper loading analysis and/or product selections. Design information and selection guidance offered by solar illuminations customer support representatives is provided as general guidelines only. The customer remains solely responsible for proper selection of the light pole, luminaire, and/or related accessories that adhere to all applicable requirements, including (but not limited to) epa design criteria, job specifications, and engineering requirements. To ensure proper selection of the light pole, luminaire, accessories and/or foundation, solar illuminations recommends the customer consult a qualified engineer to analyze the loading and design criteria for the specific application.

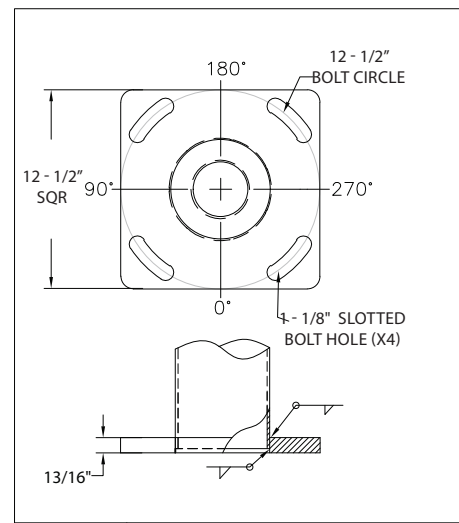
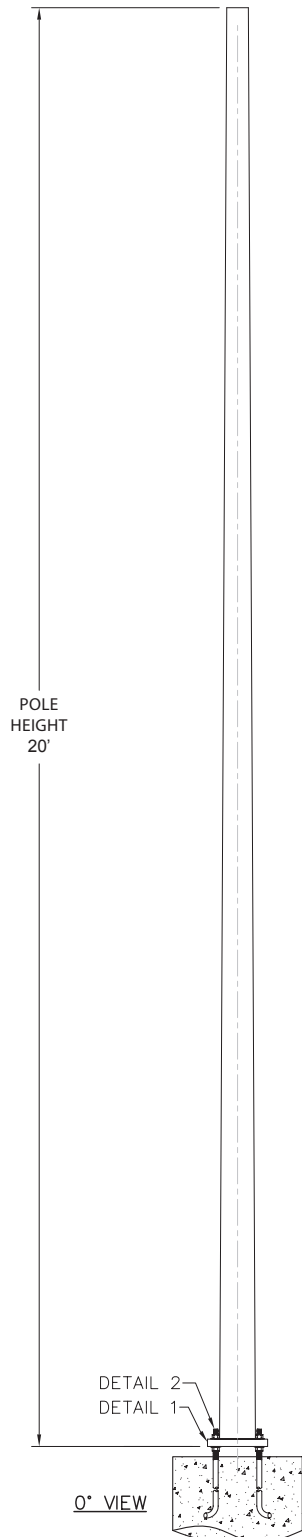

DETAIL 1 | BASE PLATE

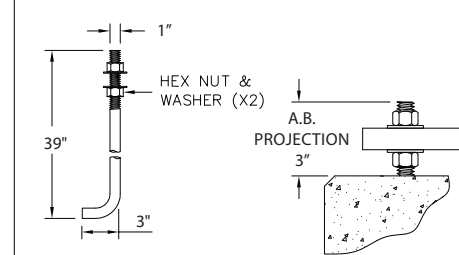

DETAIL 2 | ANCHOR BOLT

9120 Centerlinks Commerce Drive • Unit 3 • Fort Myers • FL • 33912 • USA • Telephone: 239-461-5522
 MONDAY - FRIDAY 8:00AM - 8:00PM (US EASTERN TIME)

www.solarilluminations.com • sales@solarilluminations.com



SL34

SL34 SOLAR LED STREET / PARKING LOT LIGHT
35W, 65W, 100W, 135W LED Lamp & Complete Solar Sytem

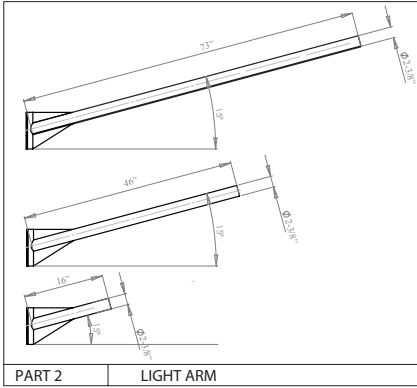

26' HD Light Pole
Steel Galvanized / Painted
Anchor Base

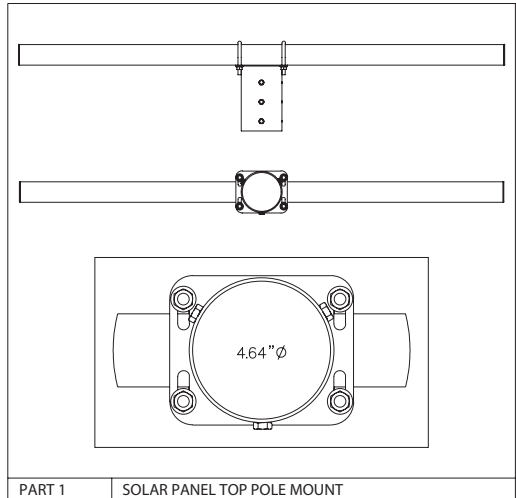

MATERIAL DATA	
COMPONENT	ASTM
POLE SHAFT	A595 GR.55
BASE PLATE	A36
ANCHOR BOLTS	F1554 GR.55
MISC. STEEL	A36

LOADING DATA	
DESIGN CRITERIA:	COMMERCIAL STANDARD
WIND SPEED (MPH) 1.3 GUST	80 90 100 110 120 130 140 150
EPA FT2	24.2 19.3 15.6 13.5 11.2 9.5 8.1 6.9
WEIGHT (LBS)	605 482 390 335 280 238 203 173

POLE DIMENSION DATA				
POLE LENGTH (FT)	BASE DIAMETER (IN)	TOP DIAMETER (IN)	GAUGE OR THICKNESS (IN)	WEIGHT (LBS)
26'	7"	3 - 3/4"	11-GA (1/8")	200

Solar illuminations poles are engineered according to AASHTO standards and accepted commercial criteria. Proper selection for an application is based on information such as EPA, wind zone, mounting height, and product attachments. This information is necessary to ensure correct engineering. Solar illuminations assumes no responsibility for proper loading analysis and/or product selections. Design information and selection guidance offered by solar illuminations customer support representatives is provided as general guidelines only. The customer remains solely responsible for proper selection of the light pole, luminaire, and/or related accessories that adhere to all applicable requirements, including (but not limited to) epa design criteria, job specifications, and engineering requirements. To ensure proper selection of the light pole, luminaire, accessories and/or foundation, solar illuminations recommends the customer consult a qualified engineer to analyze the loading and design criteria for the specific application.

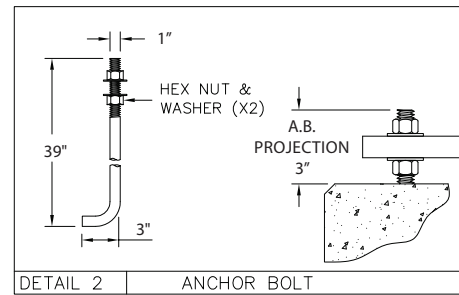
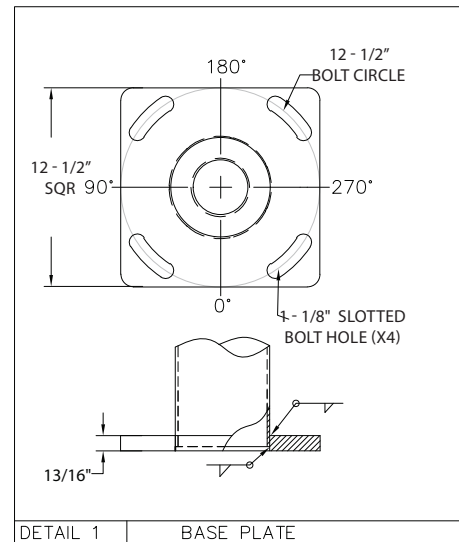
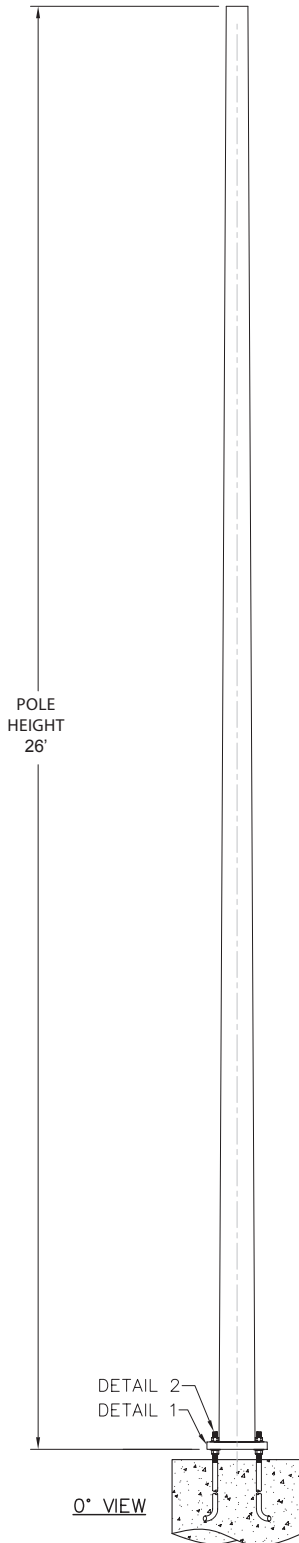

9120 Centerlinks Commerce Drive • Unit 3 • Fort Myers • FL • 33912 • USA • Telephone: 239-461-5522

MONDAY - FRIDAY 8:00AM - 8:00PM (US EASTERN TIME)

www.solarilluminations.com • sales@solarilluminations.com



SL34

SOLAR LED STREET / PARKING LOT / AREA LIGHT
35W To 135W LED Lamp - Complete System With Pole



Lowest Price* **Worldwide*** **10 Year*** **20 Year*** **Lifetime***
Guarantee Shipping System Warranty Panel Warranty Tech Support

9120 Centerlinks Commerce Drive • Unit 3 • Fort Myers • FL • 33912 • USA • Telephone: 239-461-5522

MONDAY - FRIDAY 8:00AM - 8:00PM (US EASTERN TIME)

www.solarilluminations.com • sales@solarilluminations.com

PHOTO: COURTESY OF SUN TOWER & CONSULTING, AND NETWORK POINT